

NSL5 Standard Chain Bag

NAV ID - I0062430

CODE - NSL5CB20M

The NSL5 chain bag has two straps criss-cross at the bottom to increase the loading capacity and prevent the bottom from falling through even in the case of very long chains. The chain bag has drainage holes and it is supplied with snap hooks.

- CHAIN BAG CAPACITY = 20 mtr @ 75% with 5.6 X 17mm CHAIN
- WITH HOOKS
- WITH LEATHERETTE COVER 4 SIDES

BELT TECH DATA:

- Polypropylene 5cm belt
- 25-27% elongation value
- 240 filaments
- 1100 kg Minimum Breaking Point
- 175 ° Celsius melting point

FABRIC TECH DATA:

- 840 Nylon PVC Coated
- 28-31% elongation value
- Test UNI ISO 13934-1:200
- N 502 medium breaking load value
- Test UNI 4818:1992 p.te 9

MEASUREMENTS:

- Opening = 17 x 20cm
- Length = 34cm
- Weight = 0.995 Kg
- SWL = 75Kg - 165lbs

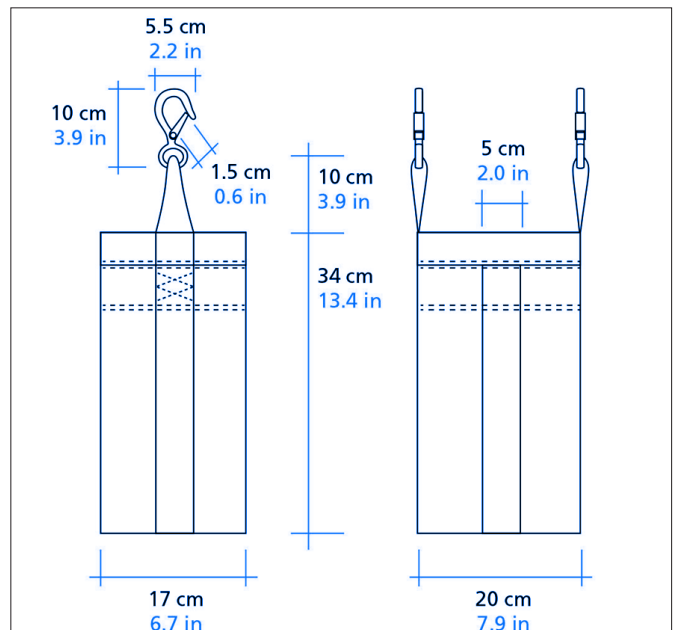
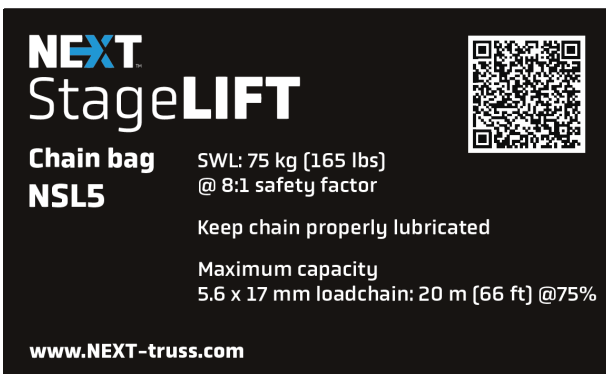
NEXT StageLIFT

Chain bag NSL5

SWL: 75 kg (165 lbs)
@ 8:1 safety factor

Keep chain properly lubricated

Maximum capacity
5.6 x 17 mm loadchain: 20 m (66 ft) @75%

www.NEXT-truss.com

